

Guidelines	60Hz	50Hz
Min. Ventilation Area--in.2 (m2)	149(0.096)	110(0.071)
Maximum Allowable Air Temperature Rise, Ambient to Engine Inlet--°F (°C)	30 (17)	30 (17)
Engine Air Flow--ft3/min (m3/min)	554 (15.7)	410 (11.6)
Maximum Air Intake Restriction		
Dirty Air Cleaner--in. H2O (kPa)	25 (6.25)	25 (6.25)
Clean Air Cleaner--in. H2O (kPa)	12 (3.0)	12 (3.0)
Intake Manifold Pressure--psi (kPa)	23 (159)	18 (121)
Eng. Heat Reject.--BTU/min (kW)	9619 (169)	9392 (165)
Eng. Radiated Heat--BTU/min (kW)	1446 (25.4)	1201 (21.1)
Coolant Flow--gal/min (L/min)	57 (216)	48 (180)
Min. Coolant Fill Rate--gal/min (L/min)	3.2 (12)	
Thermostat Start to Open--°F (°C)	160 (71)	
Thermostat Fully Open--°F (°C)	183 (84)	
Maximum Top Tank Temp--°F (°C)	212 (100)	
Minimum Sea Water-to-Boil--°F (°C)	90 (32)	
Min. Water Pump In. Press.--in. H2O (kPa)	00 (00)	
Rec'd. Pressure Cap--psi (kPa)	15 (100)	
Max. Pressure Drop		
Across Keel Cooler--psi (kPa)	4 (30)	3 (20)
Engine Coolant Capacity--qt (L)	38 (36)	38 (36)
Exhaust Gas Flow--ft3/min (m3/min)	1314 (37.2)	1035 (29)
Exhaust Temperature--°F (°C)	817 (436)	896 (480)
Min. Exhaust Pipe Dia. Dry--in. (mm)	4.5 (115)	4.0 (100)
Min. Exhaust Pipe Dia. Wet--in. (mm)	6.0 (152)	6.0 (152)
Max. Allow. Back Press.--in. H2O (kPa)		
Max. Weight on Turbo--lb (kg)	30 (7.5)	55 (25.0)
Governor Type	Electronic	
Governor Regulation	Isynchronous or Droop	
Total Fuel Flow--lb/hr (kg/hr)	608 (276)	507 (230)
Total Fuel Flow--gal/hr (L/hr)	86 (325)	71 (271)
Min. Rec'd. Fuel Line ID--in. (mm)	0.38 (10)	
Min. Rec'd. Fuel Line Size	-7	
Fuel Cons. 'Prime' --lb/hr (kg/hr)	94.3 (42.8)	78.1 (35.4)
Fuel Cons. 'Prime' --gal/hr (L/hr)	13.3 (50.3)	11.0 (41.7)
Max Leak-off Line Press.--psi (kPa)	9 (60)	
Max Leak-off Return Height--ft (m)	8 (2.5)	
Max. Fuel Trans. Pump Suction--ft (m)	10 (3.0)	
Max. Fuel Ht. Above Inj. Pump--ft (m)	10 (3.0)	
Max. Fuel Inlet Temp. w/o derate--°F (°C)	149 (65)	
Fuel Filter @ 98% Efficiency--Microns	2	

Guidelines	60Hz	50Hz
Oil Press. at Rated Speed--psi (kPa)	44 (305)	41 (280)
Oil Pressure at Low Idle--psi (kPa)	36 (250)	36 (250)
Sea Water Pump Flow--gal/min (L/min)	43 (163)	36 (136)
Max. Inlet Restriction--in. H2O (kPa)	120 (30)	120 (30)
Max. Outlet Press--psi (kPa)	20 (140)	20 (140)
Max. Suction Lift--ft (m)	10 (3.0)	10 (3.0)
Electrical System	12 Volts	24 Volts
Recommended Battery Capacity		
CCA @ 32 °F (0 °C)--amp	800	570
Max. Starting Circuit Resist.--Ohm	0.0012	0.002
Starter Rolling Current @ 32 °F (0 °C)--amp	950	600

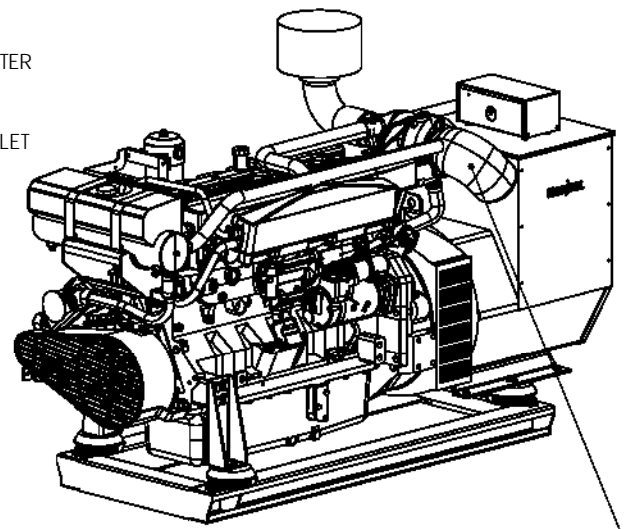

EXHAUST OUTLET (RAW WATER INJECTED)

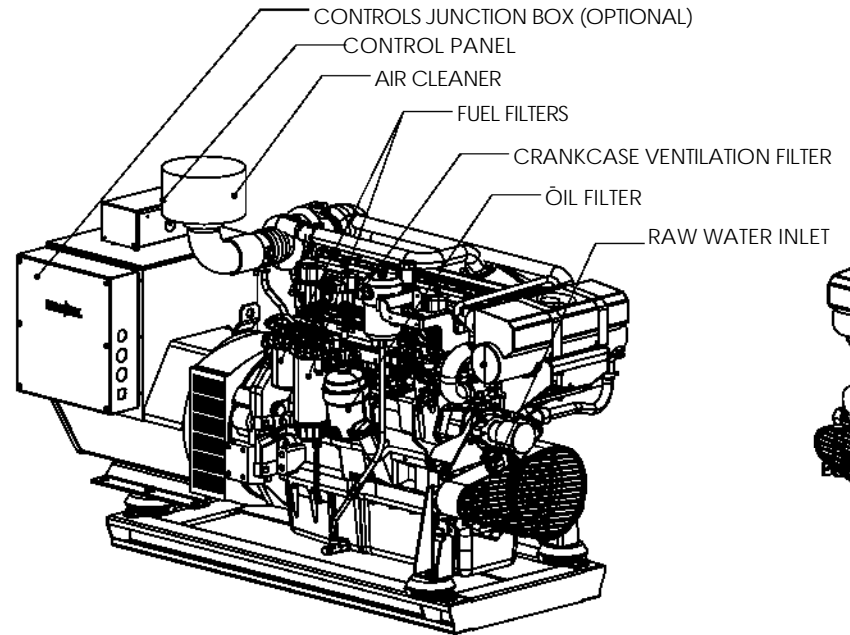
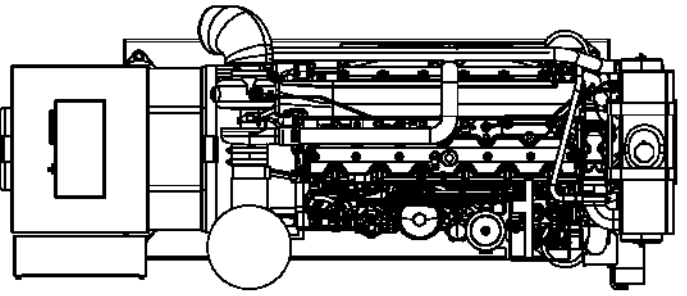
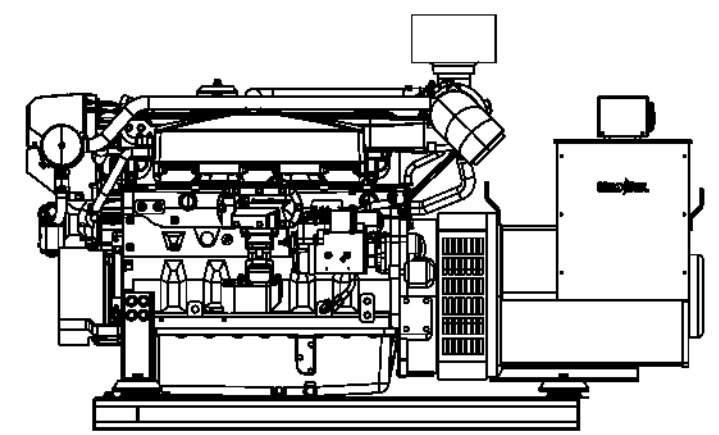
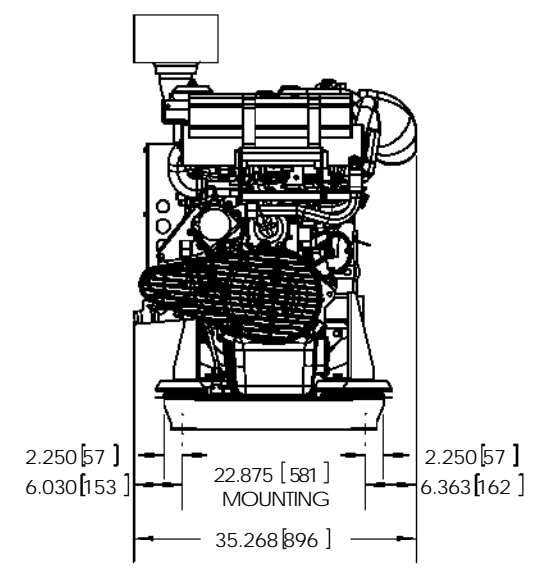
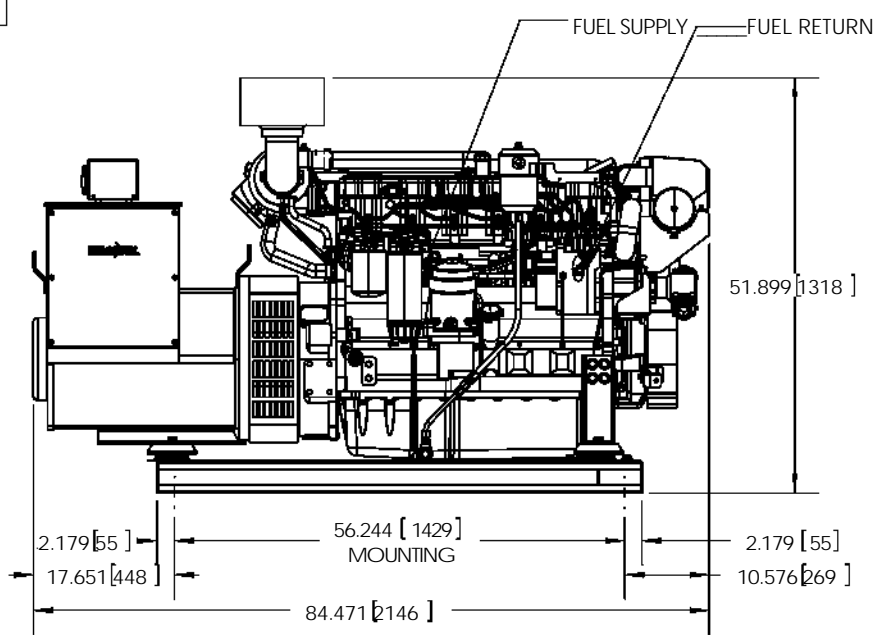
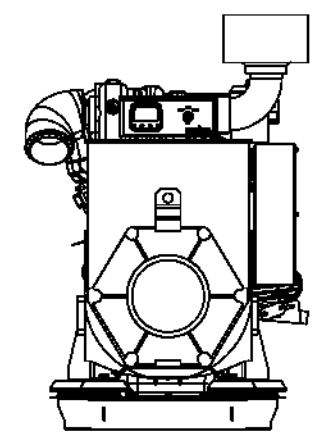

NOTE: IF BEND ORDER NOT SHOWN, BEND FLANGES FROM THE OUTSIDE IN, AND THE LONG BENDS FIRST.

REVISION	DATE	BY	ISSUED AS STANDARD PRODUCT
A	01-AUG-08	YAS	ISSUED AS STANDARD PRODUCT
SYM	DATE	BY	

<p>REAGAN EQUIPMENT COMPANY INC. 2230 PETERS ROAD HARVEY, LA 70058 504-367-1870 FAX 504-374-6487 3100 GATEWAY DRIVE POMPANO BEACH, FL 33069 954-935-0006 FAX 954-935-0010</p> <p>PROPRIETARY AND CONFIDENTIAL THE INFORMATION CONTAINED IN THIS DRAWING IS THE SOLE PROPERTY OF KILO-PAK/REAGAN EQUIPMENT COMPANY, INC. ANY REPRODUCTION IN PART OR AS A WHOLE WITHOUT THE WRITTEN PERMISSION OF KILO-PAK/REAGAN EQUIPMENT COMPANY, INC. IS PROHIBITED.</p>	DIMENSIONS ARE IN INCHES TOLERANCES: FRACTIONAL 1/32 ANGULAR: MACH 1/2 ±0.03 TWO PLACE DECIMAL ±0.010 THREE PLACE DECIMAL ±0.010	NAME: YAS DATE: 01-AUG-08	ALL BENDS UNLESS OTHERWISE SPECIFIED
	INTERPRET GEOMETRIC TOLERANCING PER: WEIGHT:	DRAWN: YAS CHECKED: ENG APPR.:	TITLE: Generator Arrangement 90-105kW @ 1500 RPM 110-130kW @ 1800 RPM
	MATERIAL: FINISH:	PROJECT: BEND ALLOWANCE:	SIZE B DWG. NO. GA08-6081AKPHE83-A REV A
	DO NOT SCALE DRAWING	PART NUMBER: 1055HKPHE83 1306HKPHE83	SCALE: 1:24 SHEET 1 OF 1