

Guidelines	60Hz	50Hz
Min. Ventilation Area--in.2 (m2)	49.6(0.032)	34.1(0.022)
Maximum Allowable Air Temperature Rise, Ambient to Engine Inlet--°F (°C)	30 (17)	30 (17)
Engine Air Flow--ft3/min (m3/min)	184 (5.2)	124 (3.5)
Maximum Air Intake Restriction		
Dirty Air Cleaner--in. H2O (kPa)	25 (6.25)	25 (6.25)
Clean Air Cleaner--in. H2O (kPa)	12 (3.0)	12 (3.0)
Intake Manifold Pressure--psi (kPa)	9.7 (67)	4.6 (32)
Eng. Heat Reject--BTU/min (kW)	3523 (62)	2681 (47)
Eng. Radiated Heat--BTU/min (kW)	564 (9.9)	404 (7.1)
Coolant Flow--gal/min (L/min)	25 (94)	14 (53)
Min. Coolant Fill Rate--gal/min (L/min)		3.2 (12)
Thermostat Start to Open--°F (°C)		180 (82)
Thermostat Fully Open--°F (°C)		203 (95)
Maximum Top Tank Temp--°F (°C)		212 (100)
Minimum Sea Water-to-Boil--°F (°C)		90 (32)
Min. Water Pump In. Press.--in. H2O (kPa)		00 (00)
Rec'd. Pressure Cap--psi (kPa)		10 (70)
Max. Pressure Drop		
Across Keel Cooler--psi (kPa)	4 (30)	3 (20)
Engine Coolant Capacity--qt (L)	15 (14)	15 (14)
Exhaust Gas Flow--ft3/min (m3/min)	463 (13.1)	300 (9.0)
Exhaust Temperature--°F (°C)	889 (476)	851 (455)
Min. Exhaust Pipe Dia. Dry--in. (mm)	2.5 (65)	2.5 (65)
Min. Exhaust Pipe Dia. Wet--in. (mm)	4.0 (100)	4.0 (100)
Max. Allow. Back Press.--in. H2O (kPa)		30 (7.5)
Max. Weight on Turbo--lb (kg)		26.5 (12.0)
Governor Type		Electronic
Governor Regulation--percent	0 to 5	0 to 6
Total Fuel Flow--lb/hr (kg/hr)	212 (96)	205 (93)
Total Fuel Flow--gal/hr (L/hr)	30 (113)	29 (109)
Min. Rec'd. Fuel Line ID--in. (mm)		0.25 (6)
Min. Rec'd. Fuel Line Size		-5
Fuel Cons. 'Prime' --lb/hr (kg/hr)	36.8 (16.7)	26.5 (12.0)
Fuel Cons. 'Prime' --gal/hr (L/hr)	5.2 (19.7)	3.7 (14.1)
Max Leak-off Line Press.--psi (kPa)		3 (20) 8
Max Leak-off Return Height--ft (m)		(2.5) 10
Max. Fuel Trans. Pump Suction--ft (m)		(3.0) 10
Max. Fuel Ht. Above Inj. Pump--ft (m)		(3.0) 212
Max. Fuel Inlet Temp. w/o derate--°F (°C)		(100)
Fuel Filter @ 98% Efficiency--Microns		2

Guidelines	60Hz	50Hz
Oil Press. at Rated Speed--psi (kPa)	50 (345)	45 (311)
Oil Pressure at Low Idle--psi (kPa)	15 (105)	15 (105)
Sea Water Pump Flow--gal/min (L/min)	22 (84)	18 (70)
Max. Inlet Restriction--in. H2O (kPa)	120 (30)	100 (25)
Max. Outlet Press--psi (kPa)	20 (135)	20 (135)
Max. Suction Lift--ft (m)	10 (3.0)	10 (3.0)
Electrical System		
Recommended Battery Capacity	12 Volts	24 Volts
CCA @ 32 °F (0 °C)--amp	640	570
Max. Starting Circuit Resist.--Ohm	0.0012	0.002
Starter Rolling Current @ 32 °F (0 °C)--amp	780	600

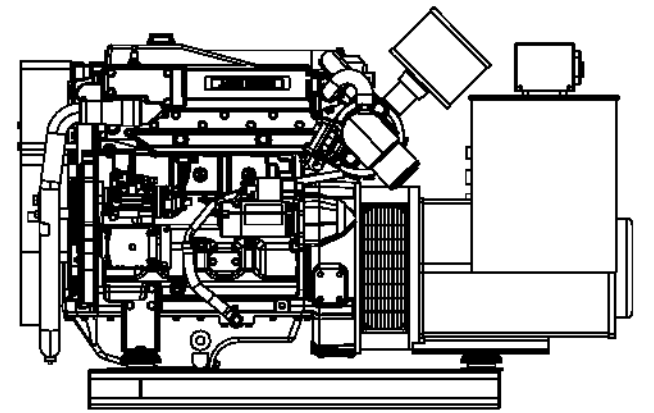
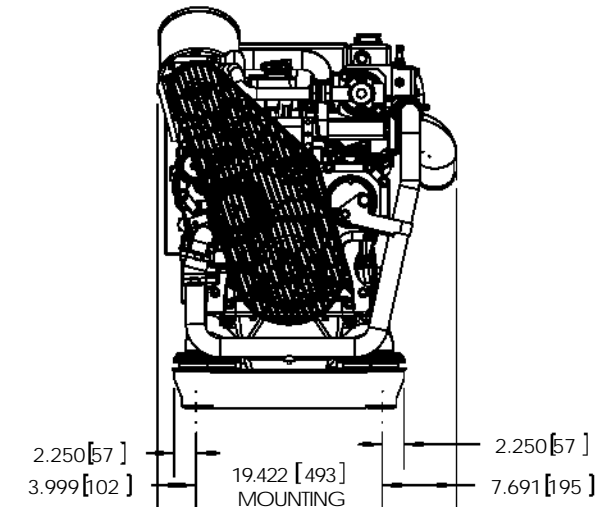
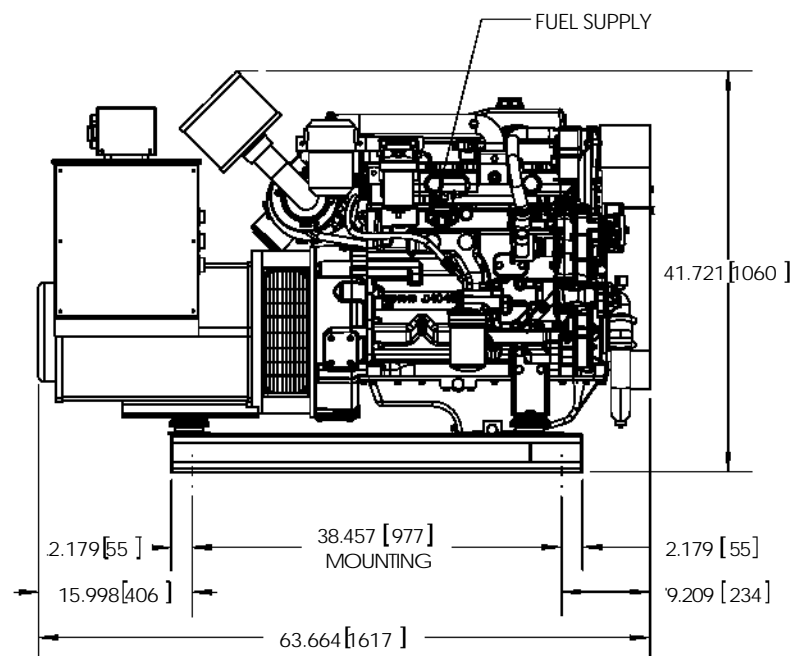
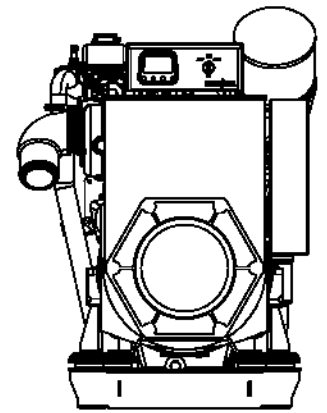
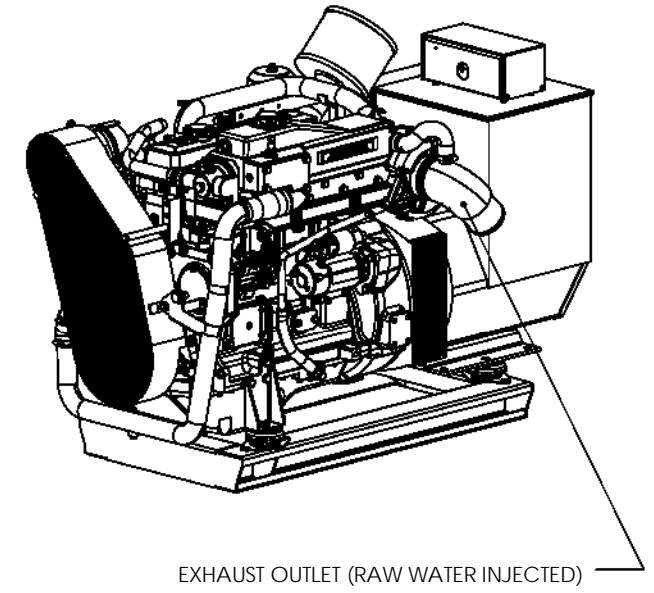
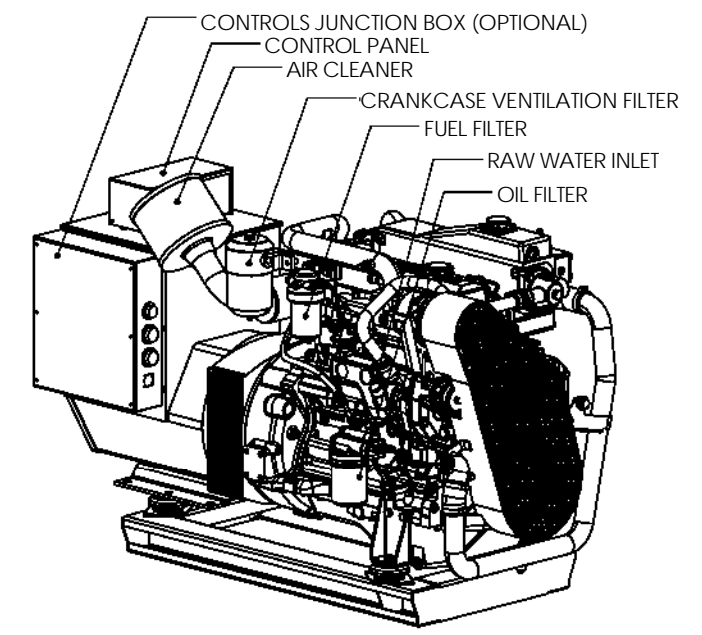
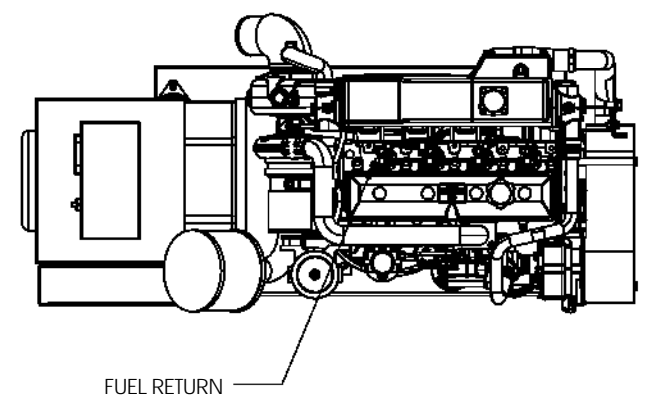

NOTE: IF BEND ORDER NOT SHOWN, BEND FLANGES FROM THE OUTSIDE IN, AND THE LONG BENDS FIRST.

REVISION	DATE	BY	ISSUED AS STANDARD PRODUCT
A	28-AUG-08	YAS	ISSUED AS STANDARD PRODUCT
SYM	DATE	BY	

<p>REAGAN EQUIPMENT COMPANY INC. 2230 PETERS ROAD HARVEY, LA 70058 504-367-1870 FAX 504-374-6487</p> <p>3100 GATEWAY DRIVE POMPANO BEACH, FL 33069 954-935-0006 FAX 954-935-0010</p> <p>PROPRIETARY AND CONFIDENTIAL THE INFORMATION CONTAINED IN THIS DRAWING IS THE SOLE PROPERTY OF KILO-PAK/REAGAN EQUIPMENT COMPANY, INC. ANY REPRODUCTION IN PART OR AS A WHOLE WITHOUT THE WRITTEN PERMISSION OF KILO-PAK/REAGAN EQUIPMENT COMPANY, INC. IS PROHIBITED.</p>	DIMENSIONS ARE IN INCHES TOLERANCES: FRACTIONAL 1/32 ANGULAR: MACH 1/2 TWO PLACE DECIMAL ±0.03 THREE PLACE DECIMAL ±0.010	NAME DATE DRAWN CHECKED ENG APPR.	ALL BENDS UNLESS OTHERWISE SPECIFIED TITLE: Generator Arrangement 37-45kW @ 1500 RPM 45-55kW @ 1800 RPM	
	INTERPRET GEOMETRIC TOLERANCING PER: WEIGHT MATERIAL FINISH DO NOT SCALE DRAWING	PROJECT BEND ALLOWANCE PART NUMBER: 0355HKPHE83 0456HKPHE83	SIZE B DWG. NO. GA08- 4045BKPHE83-A REV A	SCALE: 1:20 SHEET 1 OF 1